

**CITY OF KENOSHA
PUBLIC WORKS DEPARTMENT- ENGINEERING
LAKEFRONT LIGHTING PROJECT
LIGHT POLES, LED LUMINAIRE FIXTURES & ARM HARDWARE**

NOTICE #17-18

INSTRUCTIONS TO BIDDERS

Issued: November 28, 2018

- 1.0 Sealed bids will be accepted by the City of Kenosha, in the Department of Finance, Municipal Office Building, 625 52nd Street, Room 208, Kenosha, Wisconsin 53140 until:

Thursday December 20, 2018 at 2:00 P.M.

- for the provision and delivery of light poles, pole arms and LED luminaire fixtures per City of Kenosha specifications and cut detail provided herein. The light poles and fixtures will replace the steel lights, as part of the Harbor Park Lighting Project. Poles, arms and fixtures would be delivered to the City of Kenosha Streets Division Garage located at 6415 35th Avenue, Kenosha, WI. 53142. A separate public construction bid will be solicited in 2019.
- 2.0 The sealed bids must be completed and submitted on the included form. Submittals shall be clearly marked with the project title, notice number and the deadline date. Submittals received after the deadline shall not be considered. Forms must be signed and dated and all required documents including relevant references, literature, etc. must be included in the submission. No electronically communicated submittals will be reviewed or considered.
- 3.0 Prices shall include all costs associated with the delivery of the items to the stated location above, with no charges for packing or cartage.
- 4.0 The City of Kenosha reserves the right to reject any or all submittals or to accept the lowest responsive and responsible bidder.
- 5.0 The City of Kenosha reserves the right to increase or decrease the stated quantities by any amount up to ten-percent (10%), at the unit price stated.
- 6.0 The City of Kenosha is exempt from Federal Excise Tax and State Sales Tax, and costs should be made exclusive of any such taxes. A Tax Exemption Certificate and/or Tax Exemption Registry Number will be furnished to the successful supplier.
- 7.0 Inquiries relative to the expected products to be provided under this solicitation should be directed to Mr. James Schultz, Civil Engineer, at 262-653-4148. Inquiries relative to the solicitation process should be directed to Mr. Mark Willing, Purchasing Manager, at 262-653-4080.
- 8.0 Revisions and/or clarifications relative to this solicitation would be made only by an official City-written addenda posted at <https://www.kenosha.org/departments/finance> It would be the respondents responsibility to regularly check to see if addenda is available.

**CITY OF KENOSHA
PUBLIC WORKS DEPARTMENT- ENGINEERING
LAKEFRONT LIGHTING PROJECT
LIGHT POLES, LED LUMINAIRE FIXTURES & ARM HARDWARE**

NOTICE #17-18

SPECIFICATIONS

- 1.0 A component of the Lakefront Lighting Project is the replacement of the existing steel light poles and fixtures with new and modernized decorative light poles and LED luminaire fixtures. The intent of these specifications is to describe the light poles, pole arms, LED luminaire fixtures and requisite hardware to be supplied and to be delivered to the Department of Public Works Streets Division Garage located at 6415 35th Avenue, Kenosha, WI. 53142.
- 2.0 The intended quantity of product to be supplied and delivered is 137 decorative light poles, 185 LED luminaire fixtures, 89 single-pole bracket arms and 48 double-pole bracket arms. Requisite anchor bolts necessary for the concrete bases are included in these totals.
- 3.0 Light Poles (Twelve (12) foot. Thirteen (13) foot and fourteen (14) foot poles (in height):
 - 3.1 Cast Aluminum.
 - 3.2 Model: Cyclone – PA42.
 - 3.3 Four (4) inch diameter straight pole.
 - 3.4 Round-shaped base cover made of cast aluminum (BD 11).
 - 3.5 Color: Textured Black.
 - 3.6 To be mounted by anchor bolts (galvanized steel) to be included.
 - 3.7 Detail Sheets Attached.
- Light Poles (Eighteen (18) foot poles (in height):
 - 3.8 Cast Aluminum.
 - 3.9 Model: Cyclone – PA52.
 - 3.10 Five (5) inch diameter straight pole.
 - 3.11 Round-shaped base cover made of cast aluminum (BD 15).
 - 3.12 Color: Textured Black.
 - 3.13 To be mounted by anchor bolts (galvanized steel) to be included.
 - 3.14 Detail Sheets Attached.
- 4.0 Single - Light Pole's Bracket Arms:
 - 4.1 Aluminum.
 - 4.2 Model: Cyclone – M210.
 - 4.3 Configuration is single-arm.
 - 4.4 Height: 42 inches.
 - 4.5 Width: 24 inches.
 - 4.6 Color: Textured Black.
 - 4.7 Detail Sheets Attached.

Double - Light Pole's Bracket Arms:

- 4.8 Aluminum.
- 4.9 Model: Cyclone – M210.
- 4.10 Configuration is double-armed (C2).
- 4.11 Height: 48 inches.
- 4.12 Width: 24 inches.
- 4.13 Color: Textured Black.
- 4.14 Detail Sheets Attached.

5.0 LED Luminaire Fixtures:

- 5.1 Model & Series: Cyclone – (CN12P1A).
- 5.2 Lens: GCAS (Globe Cylinder Acrylic Satin).
- 5.3 Distribution: Five.
- 5.4 Wattage: 68 watts.
- 5.5 Voltage: 240 volts.
- 5.6 Color Temperature: 4000 Series CCT.
- 5.7 Color: Textured Black.
- 5.8 Detail Sheets Attached.

**ALUMINUM LIGHT POLES
BRACKET ARMS
LED LUMINAIRES**

MOUNTING ARMS / BRACKET

Ordering template

Bracket Configuration Mounting Options Color

M210 C1 or C2 T40 NONE BLACK-TX

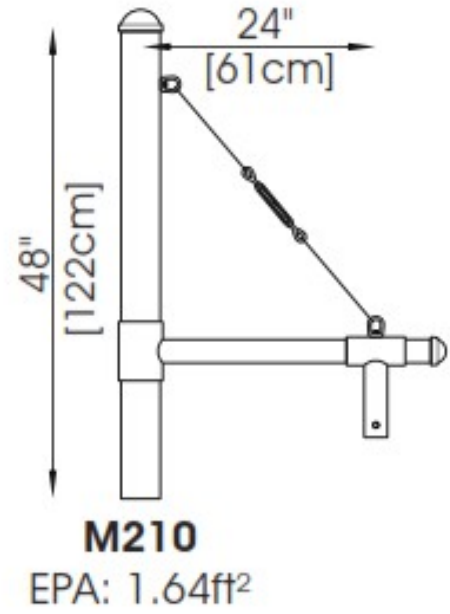
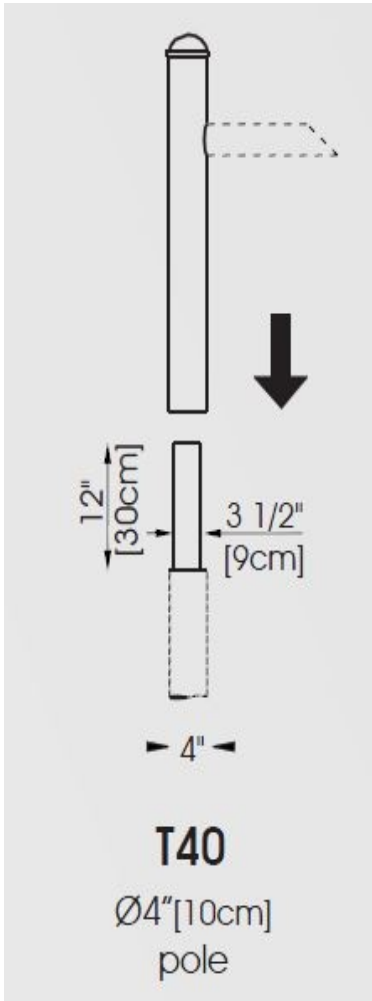
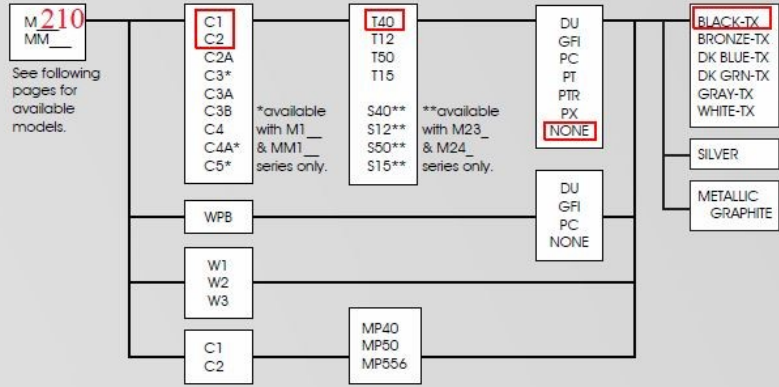

ORDERING TEMPLATE

POLE	HEIGHT	ANCHORAGE	BASE COVER	OPTIONS	COLOUR
PA42	12	SA	BD11	NONE	BLACK-TX

See first pages for codification details.

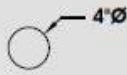

PA40 / PA42 - 4"Ø STRAIGHT POLE, ALUMINUM

POLE

Round, 4" (10cm)Ø, 6061-T6 aluminum shaft, welded to both the top and bottom of a cast aluminum reinforced anchor plate. Hand hole 2" x 5" (8cm x 12cm) with weatherproof cover and copper ground lug.

BASE COVER

BS15: Square shape. Two-piece formed aluminium alloy 1100 base cover. Mechanically secured together.
 BD_: Round shape. Two-piece base cover made of cast aluminium. Mechanically secured together.

EPA

	HEIGHT		WALL THICKNESS		WEIGHT		EPA RATING (sq. ft)					ANCHOR BOLTS	
	ft	m	in	mm	lbs	kg	80mph	90mph	100mph	110mph	120mph	150mph	in
PA40	8	2.44	0.125	3.2	19	9	13.6	10.4	8.2	6.5	5.3	3.3	3/4-20
PA42	8	2.44	0.226	5.7	30	14	24.4	19.0	15.1	12.3	10.1	6.3	3/4-20
PA40	10	3.05	0.125	3.2	23	10	10.4	7.9	6.0	4.7	3.7	2.2	3/4-20
PA42	10	3.05	0.226	5.7	36	16	19.3	14.9	11.7	9.4	7.7	4.7	3/4-20
PA40	12	3.66	0.125	3.2	27	12	8.1	5.9	4.4	3.3	2.5	1.4	3/4-20
PA42	12	3.66	0.226	5.7	42	19	15.5	11.8	9.2	7.2	5.8	3.5	3/4-20
PA40	13	3.96	0.125	3.2	29	13	7.1	5.1	3.7	2.7	2.0	1.1	3/4-20
PA42	13	3.96	0.226	5.7	46	21	14.0	10.6	8.2	6.3	5.0	3.0	3/4-20
PA40	14	4.27	0.125	3.2	31	14	6.2	4.4	3.1	2.1	1.5	-	3/4-20
PA42	14	4.27	0.226	5.7	49	22	12.7	9.5	7.2	5.6	4.4	2.5	3/4-20
PA40	15	4.57	0.125	3.2	32	15	5.4	3.7	2.5	1.6	1.0	-	3/4-20
PA42	15	4.57	0.226	5.7	52	24	11.5	8.5	6.4	4.8	3.7	2.1	3/4-20
PA40	16	4.88	0.125	3.2	34	15	4.7	3.1	2.0	1.2	-	-	3/4-20
PA42	16	4.88	0.226	5.7	55	25	10.4	7.6	5.6	4.2	3.1	1.7	3/4-20
PA42	18	5.49	0.226	5.7	61	28	8.2	5.9	4.2	2.9	2.0	1.0	1-36
PA42	20	6.10	0.226	5.7	68	31	6.5	4.4	2.9	1.8	1.1	-	1-36

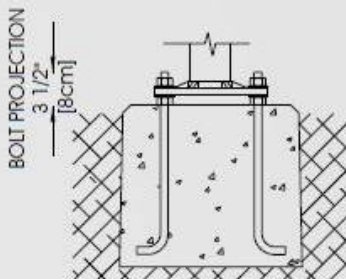
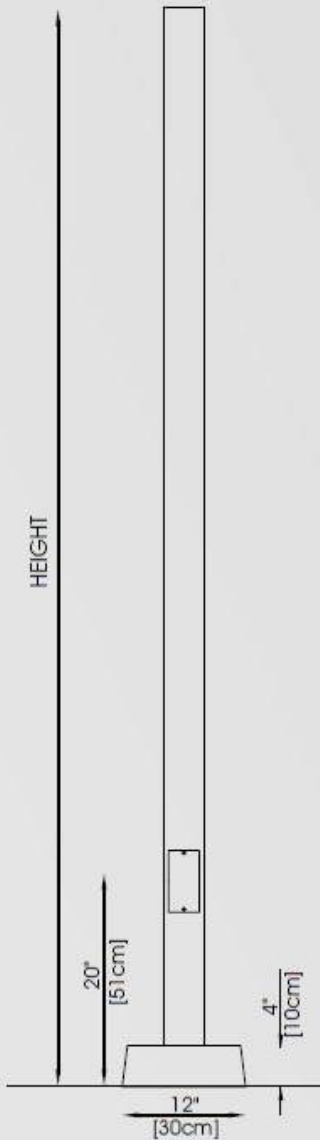

BOLT CIRCLE

Anchor plate (SA or TB_)

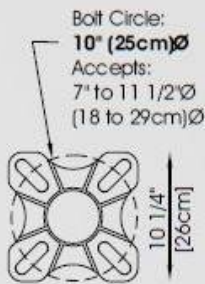

Pole with anchor plate, supplied with galvanized anchor bolts, nuts & washers.

ANCHORAGE

Anchor plate (SA)

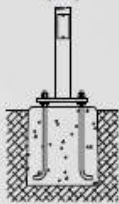

Tenon base (TB_)



Pier mount (SAP)



Direct burial (DB_)

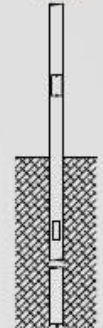

BASE COVERS (examples)

BS15 is shown with the pole.
 For all models available, see "Pole options" Section.

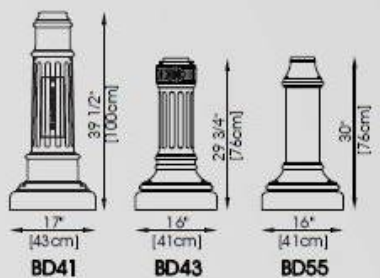

BASE COVERS / STANDARD

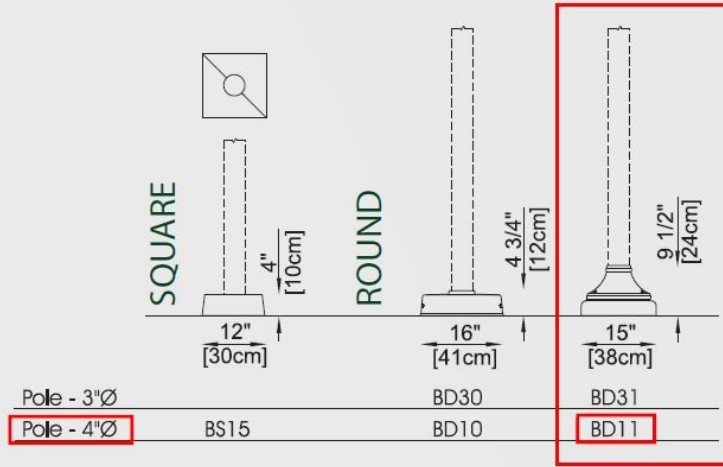

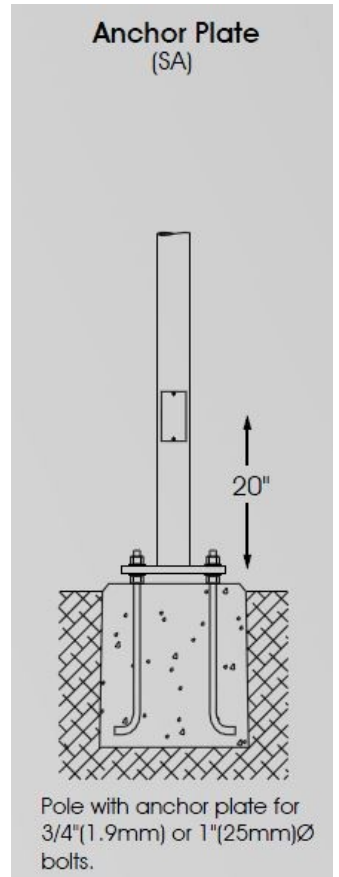
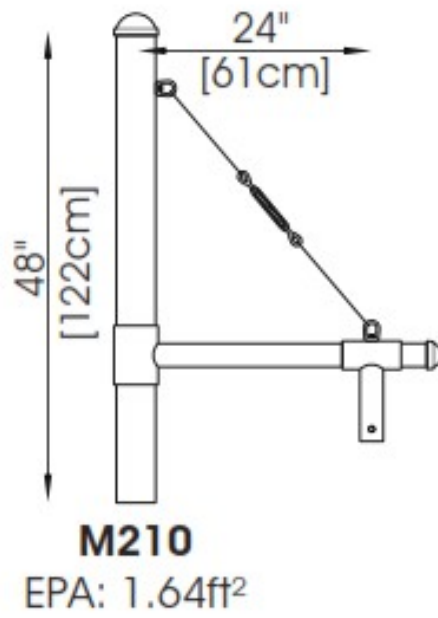
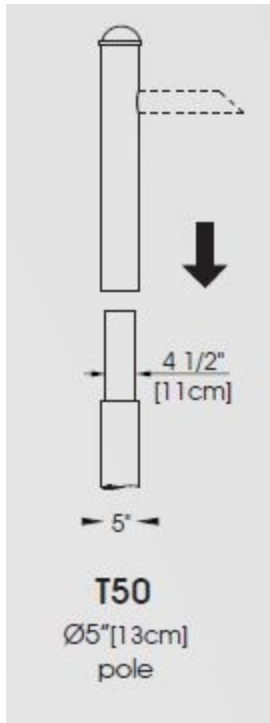

ORDERING TEMPLATE

POLE	HEIGHT	ANCHORAGE	BASE COVER	OPTIONS	COLOUR
PA52	18	SA	BD15	NONE	BLACK-TX

See first pages for codification details.

PA50 / PA52 - 5"Ø STRAIGHT POLE, ALUMINUM

POLE

Round, 5" (13cm)Ø, 6061-T6 aluminum shaft, welded to both the top and bottom of a cast aluminum reinforced anchor plate. Hand hole 2" x 5" (8cm x 12cm) with weatherproof cover and copper ground lug.

Handhole 2" x 5" (8cm x 12 cm) with weatherproof cover and copper ground lug.

BASE COVER

BS15: Square shape. Two-piece formed aluminium alloy 1100 base cover. Mechanically secured together.

BD_: Round shape. Two-piece base cover made of cast aluminium. Mechanically secured together.

EPA

	HEIGHT		WALL THICKNESS		WEIGHT		EPA RATING (sq. ft)						ANCHOR BOLTS
	ft	m	in	mm	lbs	kg	80mph	90mph	100mph	110mph	120mph	150mph	In
PA50	12	3.66	0.125	3.2	36	17	13.7	10.3	8.1	6.5	5.4	3.2	3/4-20
PA52	12	3.66	0.250	6.3	61	28	28.6	22.1	17.6	14.4	12.0	7.5	3/4-20
PA50	14	4.27	0.125	3.2	41	19	11.0	8.0	6.2	4.9	4.0	2.3	3/4-20
PA52	14	4.27	0.250	6.3	70	32	23.9	18.2	14.4	11.8	9.8	6.0	3/4-20
PA50	15	4.57	0.125	3.2	43	20	9.8	7.1	5.4	4.3	3.4	1.9	3/4-20
PA52	15	4.57	0.250	6.3	74	34	21.9	16.6	13.1	10.7	8.8	5.4	3/4-20
PA50	16	4.88	0.125	3.2	45	21	8.8	6.2	4.6	3.6	2.9	1.6	3/4-20
PA52	16	4.88	0.250	6.3	79	36	20.1	15.1	11.9	9.6	7.9	4.8	3/4-20
PA50	18	5.49	0.125	3.2	50	23	6.7	4.5	3.2	2.5	1.9	-	1-36
PA52	18	5.49	0.250	6.3	87	40	16.6	12.3	9.5	7.7	6.3	3.7	1-36
PA50	20	6.10	0.125	3.2	54	25	5.0	3.1	2.0	1.5	1.0	-	1-36
PA52	20	6.10	0.250	6.3	96	44	13.7	10.0	7.6	6.1	4.9	2.8	1-36

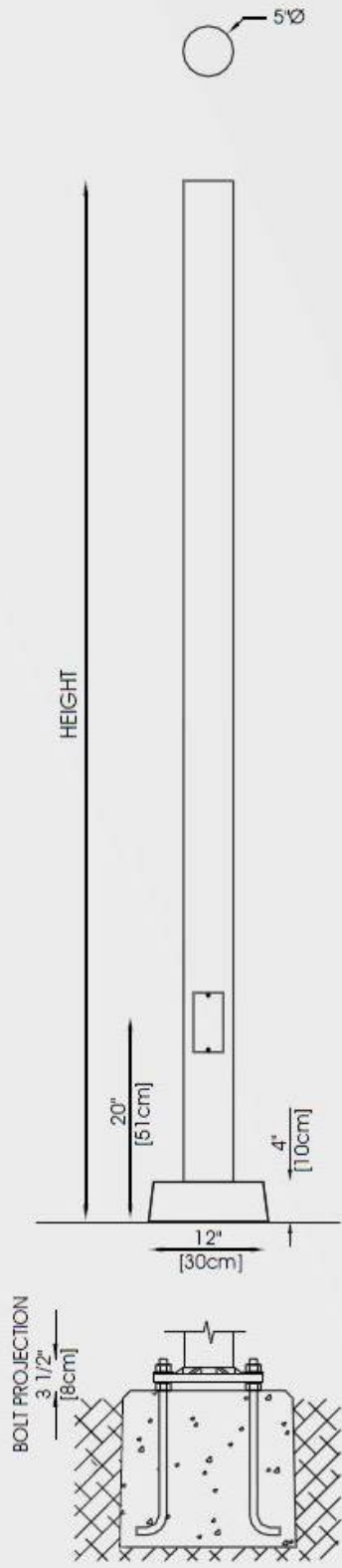

BOLT CIRCLE

Anchor plate (SA)

Bolt Circle: 11 1/2" (29cm)Ø
Accepts: 8" to 12"Ø (20 to 30cm)Ø

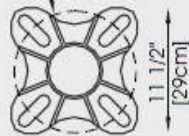

Pole with anchor plate, supplied with galvanized anchor bolts, nuts & washers.

ANCHORAGE

Anchor plate (SA)

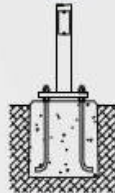

Tenon base (TB_)



Pier mount (SAP)



Direct burial (DB_)

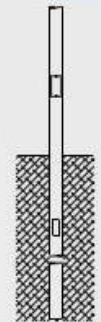

BASE COVERS (examples)

BS16 is shown with the pole. For all models available, see "Pole options" Section.

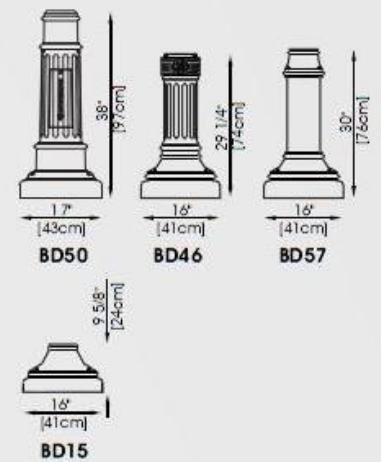

**CITY OF KENOSHA
PUBLIC WORKS DEPARTMENT- ENGINEERING
LAKEFRONT LIGHTING PROJECT
LIGHT POLES, LED LUMINAIRE FIXTURES & ARM HARDWARE**

NOTICE #17-18

BASE BID DETAIL:	QUANTITY:	UNIT:	UNIT COST:	EXTENDED COST:
SUPPLY LED FIXTURES	185	EA.	\$	\$
SUPPLY SINGLE-POLE BRACKET ARMS	89	EA.	\$	\$
SUPPLY DOUBLE-POLE BRACKET ARMS	48	EA.	\$	\$
SUPPLY TWELVE (12) FT. ALUMINUM DECORATIVE LIGHT POLES (INCL. REQUISITE ANCHOR BOLTS)	4	EA.	\$	\$
SUPPLY THIRTEEN (13) FT. ALUMINUM DECORATIVE LIGHT POLES (INCL. REQUISITE ANCHOR BOLTS)	34	EA.	\$	\$
SUPPLY FOURTEEN (14) FT. ALUMINUM DECORATIVE LIGHT POLES (INCL. REQUISITE ANCHOR BOLTS)	91	EA.	\$	\$
SUPPLY EIGHTEEN (18) FT. ALUMINUM DECORATIVE LIGHT POLES (INCL. REQUISITE ANCHOR BOLTS)	8	EA.	\$	\$
TOTAL COST:				\$

Delivery shall be made within _____ days or _____ days of receipt of Purchase Order.

Submitted By:

Firm Name: _____

Signature: _____

Print Name: _____

Firm Address: _____

Firm Phone No.: _____ Firm FAX: _____

E-mail: _____

Date: _____

PAYMENT TERMS: _____% _____, NET _____ DAYS