

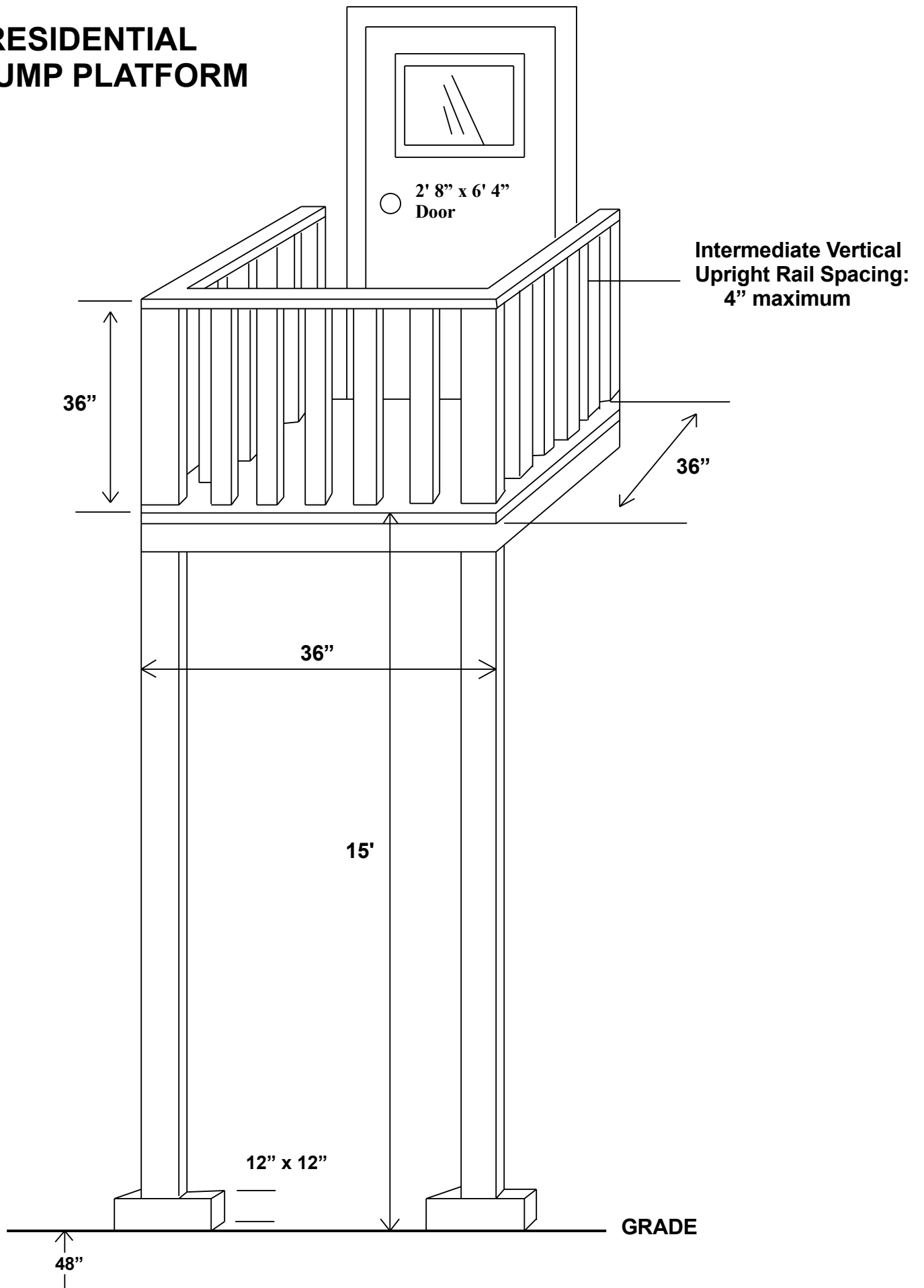

## CONSTRUCTION GUIDELINES STAIRS / PLATFORMS / GUARDRAILS / EXIT DOORS

	1 & 2 FAMILY DWELLING	MULTI-FAMILY (3 OR MORE UNITS)	COMMERCIAL, MANUFACTURING, INSTITUTIONAL
<b>STAIR WIDTH</b>	36" minimum	36" minimum	44" minimum
<b>TREAD WIDTH</b>	9" minimum	10" minimum	11" minimum
<b>RISER HEIGHT</b>	8" maximum	7 3/4" maximum No open risers	4" minimum 7" maximum No open risers
<b>HANDRAIL HEIGHT</b> (not required if less than three risers)	30" min / 38" max 1 1/2" wall clearance	34" min / 38" max 1 1/2" wall clearance	34" min / 38" max 1 1/2" wall clearance
<b>HANDRAIL DIMENSION</b>  (Note: 2x4's and 2x6's are not permitted for use as a handrail)	<b>Round:</b> 2" maximum <b>Rectangle:</b> 2 7/8" (grip) maximum	<b>Round:</b> 1 1/2" minimum <b>Round:</b> 2" maximum <b>Rectangle:</b> 2 7/8" (grip) maximum	<b>Round:</b> 1 1/2" minimum <b>Round:</b> 2" maximum <b>Rectangle:</b> 2 7/8" (grip) maximum
<b>HEADROOM (Stairs)</b>	76" minimum	80" minimum	80" minimum
<b>LANDINGS</b>	36" x 36" minimum	36" x the width of stairs minimum	44" x the width of stairs minimum
<b>GUARDRAIL HEIGHT</b> (not required on 24" or less elevation)	36" minimum	36" minimum	42" minimum
<b>INTERMEDIATE VERTICAL UPRIGHT SPACING</b>	4" maximum	4" maximum	4" maximum
<b>EXIT DOOR SIZE</b>	36" x 80" minimum	36" x 78" minimum	36" x 80" minimum
<b>JUMP PLATFORM</b>	36" x 36" minimum <b>Maximum grade clearance:</b> 15'	14 sq. ft. with minimum dimension of 3' <b>Maximum grade clearance:</b> 15'	14 sq. ft. with minimum dimension of 3' <b>Maximum grade clearance:</b> 15'

# RESIDENTIAL JUMP PLATFORM



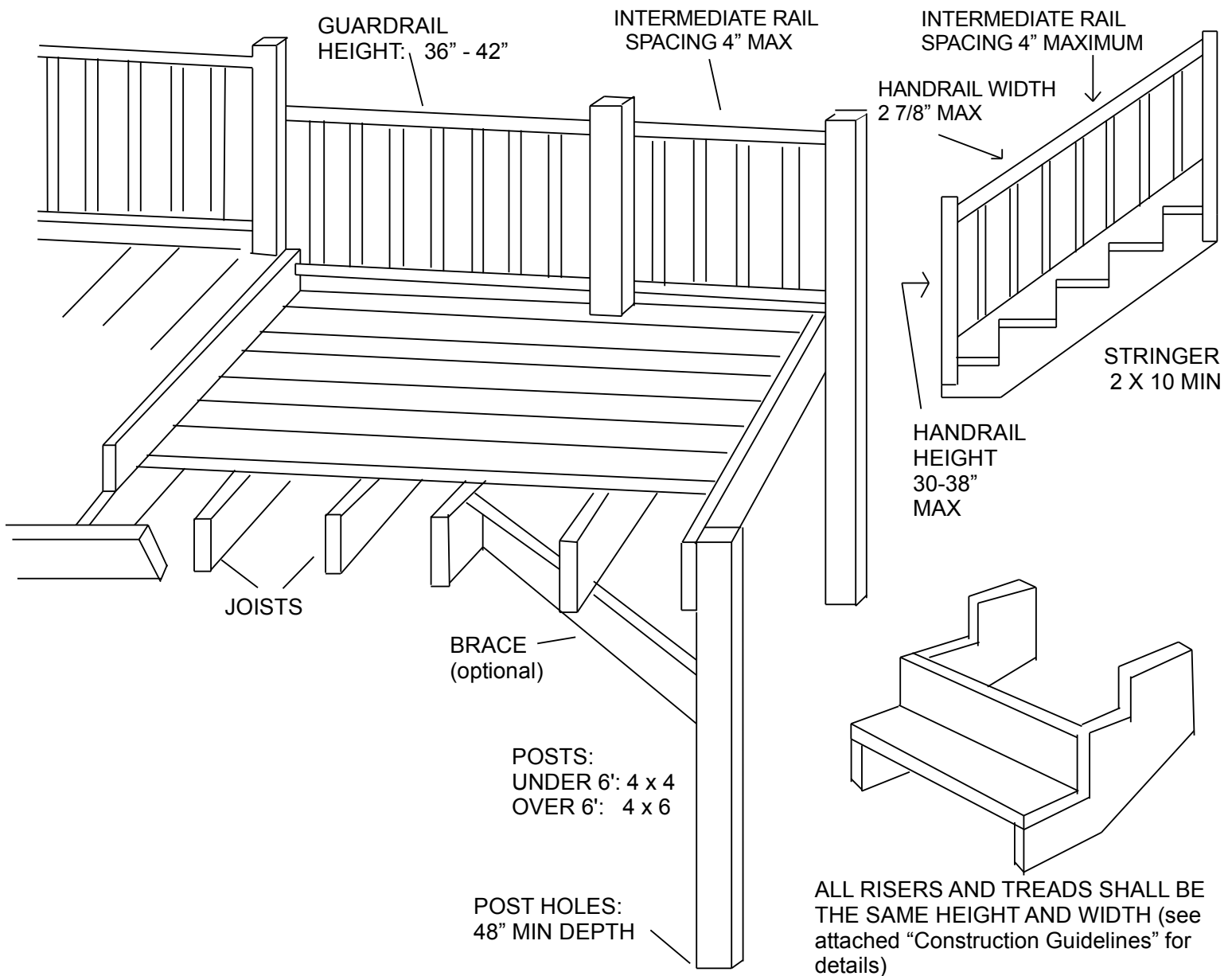

**MAXIMUM JOIST SPANS AND SPACING**

<b>JOIST SIZE</b>	<b>WOOD SPECIES</b>	<b>MAXIMUM SPAN</b>
For 16-inch Joist Spacing: 2 x 6	Douglas Fir	9' 9"
	Ponderosa Pine	8' 7"
2 x 8	Douglas Fir	12' 10"
	Ponderosa Pine	11' 4"
2 x 10	Douglas Fir	16' 5"
	Ponderosa Pine	14' 5"
For 24-inch Joist Spacing: 2 x 6	Douglas Fir	8' 6"
	Ponderosa Pine	7' 6"
2 x 8	Douglas Fir	11' 3"
	Ponderosa Pine	9' 11"
2 x 10	Douglas Fir	14' 4"
	Ponderosa Pine	12' 3"

**ALL LUMBER TO BE PRESSURE TREATED**

# EXAMPLE AND MATERIALS LIST FOR DECK (side view cut away)

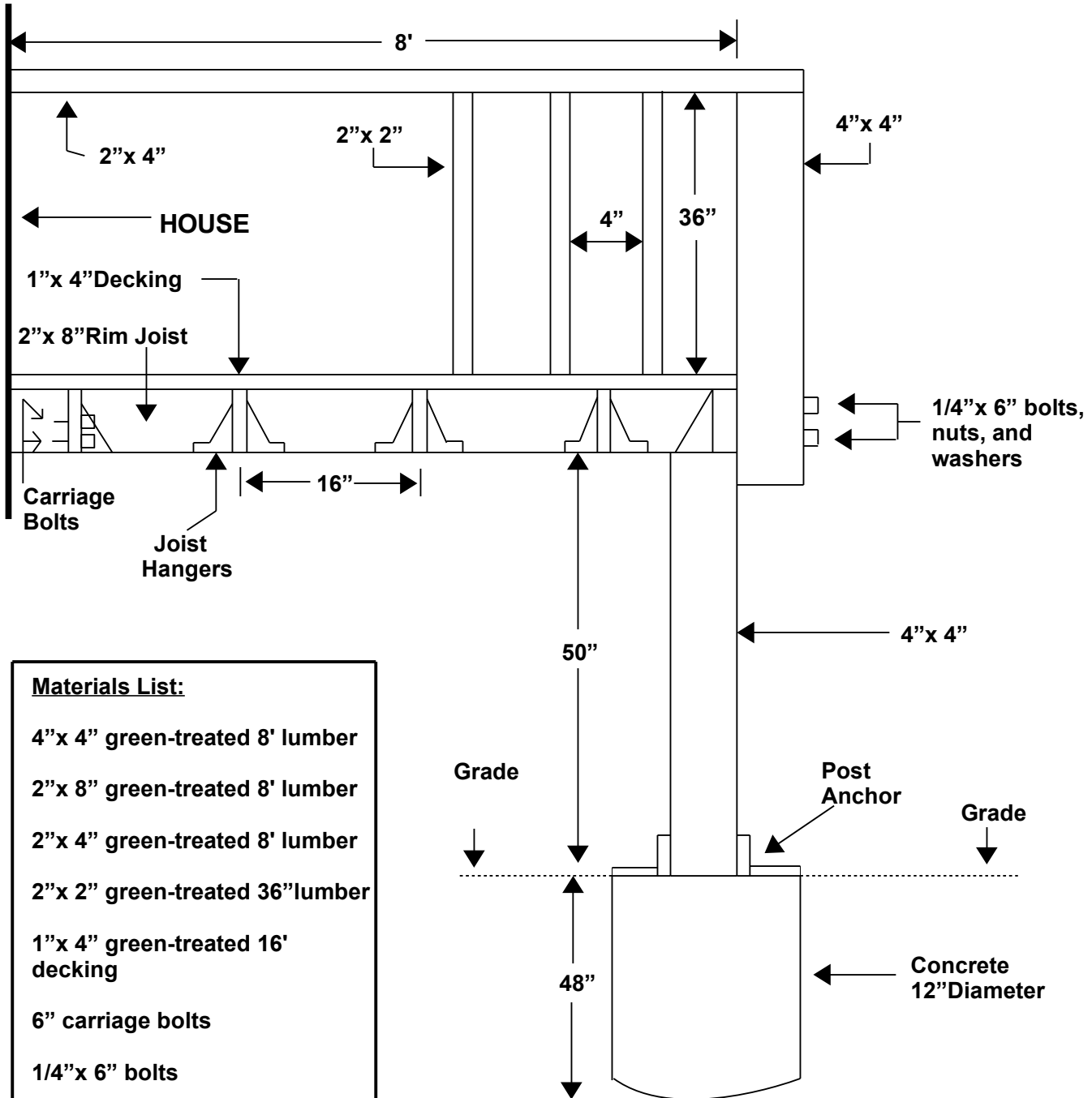

### Materials List:

- 4" x 4" green-treated 8' lumber
- 2" x 8" green-treated 8' lumber
- 2" x 4" green-treated 8' lumber
- 2" x 2" green-treated 36" lumber
- 1" x 4" green-treated 16' decking
- 6" carriage bolts
- 1/4" x 6" bolts
- 1/4" nuts and washers
- Post anchors
- 1 lb. nails
- 3 lb. nails

## **Porch and Deck Regulations for Zoning Districts RG1, RG2, and RS3**

### **Porches and Decks:**

1. A porch constructed with a new home, which either encroaches or does not encroach into the setback, must be:
  - No more than six feet (6') into required setback
  - A minimum of 25 square feet with six feet (6') depth
  - Roofed
  - Perimeter to be defined by use of columns, posts, railings, etc.
  - Conforming with all other applicable codes and ordinances
  
2. The covered porch or deck may encroach into the required side or rear yard not more than six feet (6') or 20% of the required yard, whichever is less.

**For handrail shapes (from the Wisconsin Department of Commerce, Safety and Buildings Division) please see the following website:**

**<http://dsps.wi.gov/sb/SB-DivCodesListing.html#20>**

Under **Uniform Dwelling Code** SPS 320-325, click on SPS 320-325 Appendix.  
See page 51.